

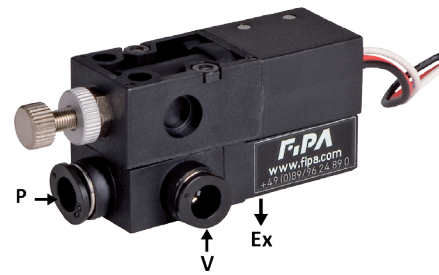

EBO – Ejector boxes



Series "-S" with mechanical vacuum switch

□ = Vacuum connection □ = Compressed air connection □ = Exhaust outlet (R)

Product notes

- > High suction power for fast evacuation and short gripping time
- > Easy installation directly in the vacuum line
- > Rectangular design enables space-conserving parallel mounting of several ejector boxes
- > Replaceable silencer filter element
- > Compressed air and vacuum connection via quick fittings, exhaust via rectangular silencer

Type -S with mechanical / electrical vacuum switch:

- > Monitoring of vacuum circuits for high process reliability
- > NO/NC switching function
- > Factory setting: -534 mbar (-7.7 psi)
- > Contact capacity: 3 A at 250 V
- > Regulating range: -200 to -667 mbar (-2.9 to -9.7 inHg)
- > Repeat accuracy: ± 50 mbar (± 1.5 inHg)
- > Hysteresis: -200 mbar (-2.9 inHg)

Ordering notes

- > Index H: Ejectors for dense products (max. vacuum degree 90 %)
- > Index L: Ejectors for porous products, resp. in case of higher leakage (increased suction, max. vacuum degree 68 %)
- > Index P: Ejectors designed for lower feed pressure (max. vacuum degree 90 %)

Technical data

Item no.	Nozzle diameter [mm]	Optimal operating pressure [bar (psi)]	Final vacuum [%]	Suction power [Nl/min]	Air consumption [Nl/min]	Operating temperature [°C (°F)]	Weight [g]	Suitable filter and silencer-set
EBO.05H.4	0.5	5 (72.5)	90	7	11.5	0 - 60 (32 - 140)	18	72.105
EBO.07H.1	0.7	5 (72.5)	93	13	23	0 - 60 (32 - 140)	18.5	72.105
EBO.10H.1	1	5 (72.5)	93	28	46	0 - 60 (32 - 140)	18.5	72.105
EBO.12H.1	1.2	5 (72.5)	93	38	70	0 - 60 (32 - 140)	18	72.105
EBO.05L.4	0.5	5 (72.5)	68	12	11.5	0 - 60 (32 - 140)	18	72.105
EBO.07L.1	0.7	5 (72.5)	68	26	23	0 - 60 (32 - 140)	18.5	72.105
EBO.10L.1	1	5 (72.5)	68	42	46	0 - 60 (32 - 140)	17.5	72.105
EBO.07P.1	0.7	3.5 (50.8)	90	10.5	17	0 - 60 (32 - 140)	18.5	72.105
EBO.10P.1	1	3.5 (50.8)	90	21	34	0 - 60 (32 - 140)	18.5	72.105
EBO.12P.1	1.2	3.5 (50.8)	90	27	47	0 - 60 (32 - 140)	18	72.105
EBO.05H.4-S	0.5	5 (72.5)	90	7	11.5	0 - 60 (32 - 140)	46.5	72.105
EBO.07H.1-S	0.7	5 (72.5)	93	13	23	0 - 60 (32 - 140)	46	72.105
EBO.10H.1-S	1	5 (72.5)	93	28	46	0 - 60 (32 - 140)	47	72.105
EBO.12H.1-S	1.2	5 (72.5)	93	38	70	0 - 60 (32 - 140)	47.5	72.105
EBO.05L.4-S	0.5	5 (72.5)	68	12	11.5	0 - 60 (32 - 140)	46.5	72.105
EBO.10L.1-S	1	5 (72.5)	68	42	46	0 - 60 (32 - 140)	46.5	72.105
EBO.07P.1-S	0.7	3.5 (50.8)	90	10.5	17	0 - 60 (32 - 140)	48.5	72.105
EBO.10P.1-S	1	3.5 (50.8)	90	21	34	0 - 60 (32 - 140)	48.5	72.105
EBO.12P.1-S	1.2	3.5 (50.8)	90	27	47	0 - 60 (32 - 140)	47.5	72.105



Model selection

Ordering example:

EBO.05H.4 = Nozzle diam. 0.5 mm for dense products, hose diam. 4 mm, without vacuum switch

EBO.07L.1-S = Nozzle diam. 0.7 mm for porous products, hose diam. 6 mm, with mechanical / electrical vacuum switch

Serie	Nozzle diameter	Type	Hose diameter	Vacuum switch
EBO.	05 = 0.5 mm 07 = 0.7 mm 10 = 1.0 mm	H = for dense products L = for porous products P = for lower feed pressure	.1 = 6 mm .4 = 4 mm	-S (with) blank (without)

Dimensions

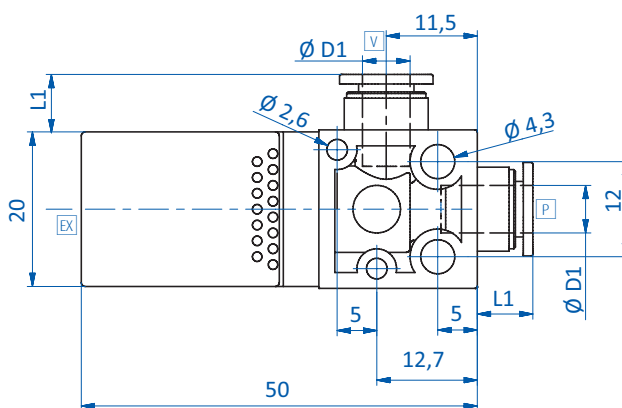

EBO.05H.4 | EBO.07H.1 | EBO.10H.1 | EBO.12H.1 | EBO.05L.4 | EBO.07L.1 | EBO.10L.1 | EBO.07P.1 | EBO.10P.1 | EBO.12P.1

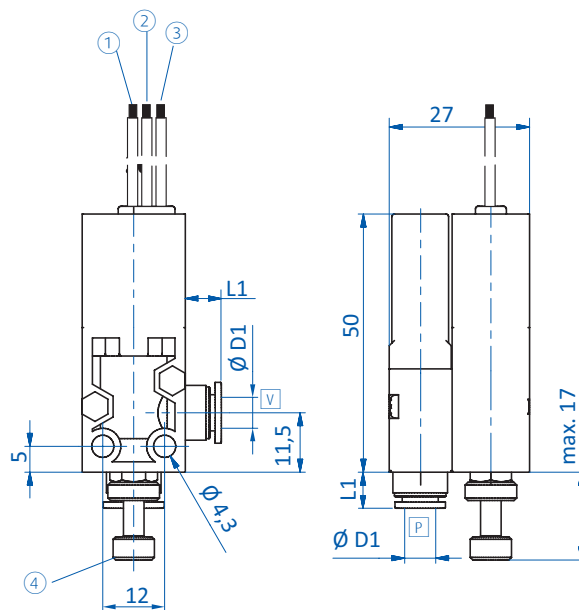

EBO.05H.4-S | EBO.07H.1-S | EBO.10H.1-S | EBO.12H.1-S | EBO.05L.4-S | EBO.10L.1-S | EBO.07P.1-S | EBO.10P.1-S | EBO.12P.1-S

P = Compressed air side with tubing connection V = Vacuum side with tubing connection EX = Exhaust outlet (R) ① = White ② = Red (NC)
③ = Black (NO) ④ = Knurled screw



Vacuum generation | Ejector boxes

EBO – Ejector boxes

Item no.	Ø D1 [mm]	L1 [mm]
EBO.05H.4	4	6.6
EBO.07H.1	6	7
EBO.10H.1	6	7
EBO.12H.1	6	7
EBO.05L.4	4	6.6
EBO.07L.1	6	7
EBO.10L.1	6	7
EBO.07P.1	6	7
EBO.10P.1	6	7
EBO.12P.1	6	7
EBO.05H.4-S	4	6.6
EBO.07H.1-S	6	7
EBO.10H.1-S	6	7
EBO.12H.1-S	6	7
EBO.05L.4-S	4	6.6
EBO.10L.1-S	6	7
EBO.07P.1-S	6	7
EBO.10P.1-S	6	7
EBO.12P.1-S	6	7



Diagrams

> Suction power and air consumption against feed pressure

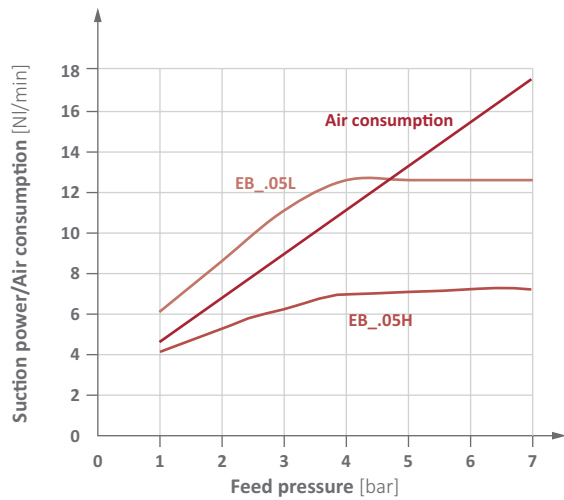

> Vacuum level against feed pressure

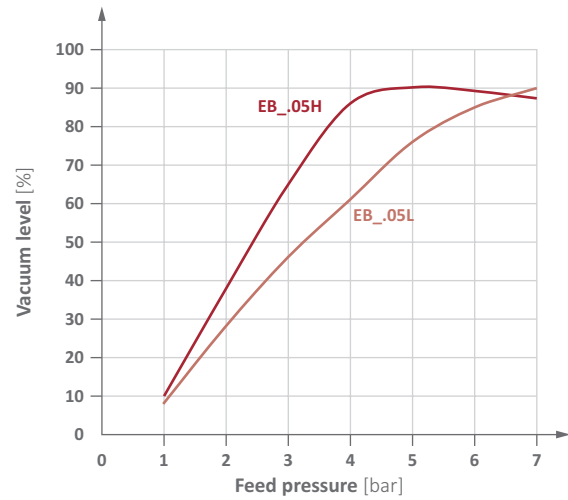

> Suction power and air consumption against feed pressure

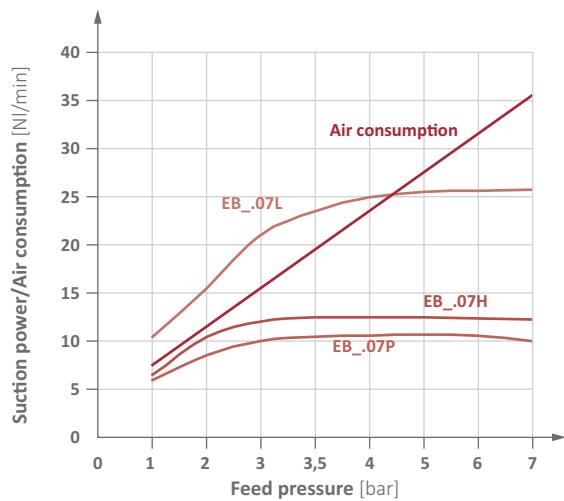

> Vacuum level against feed pressure

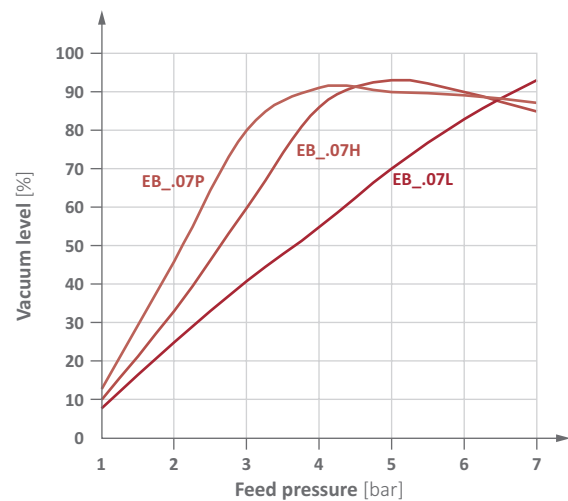

> Suction power and air consumption against feed pressure

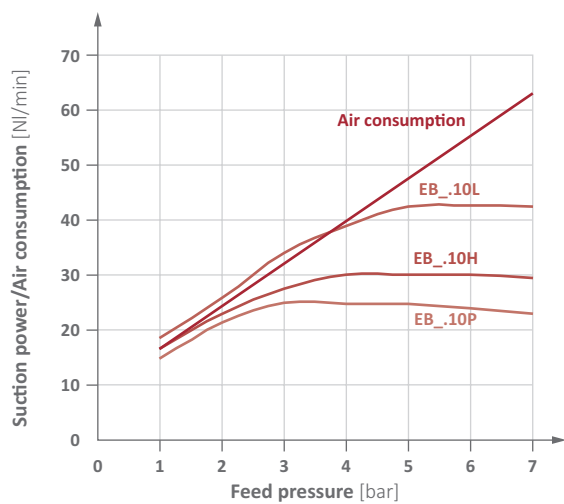

> Vacuum level against feed pressure

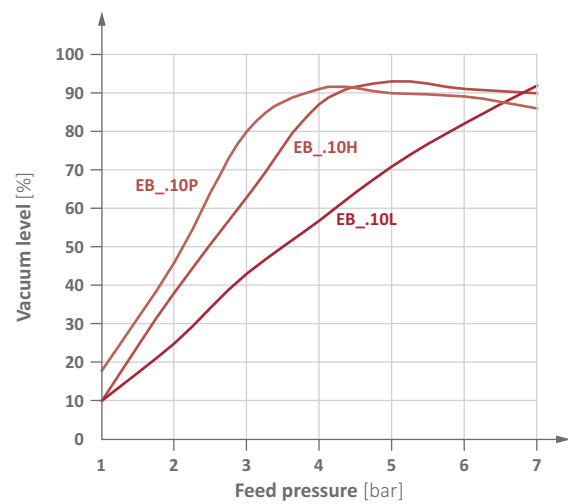



Diagrams

> Suction power and air consumption against feed pressure

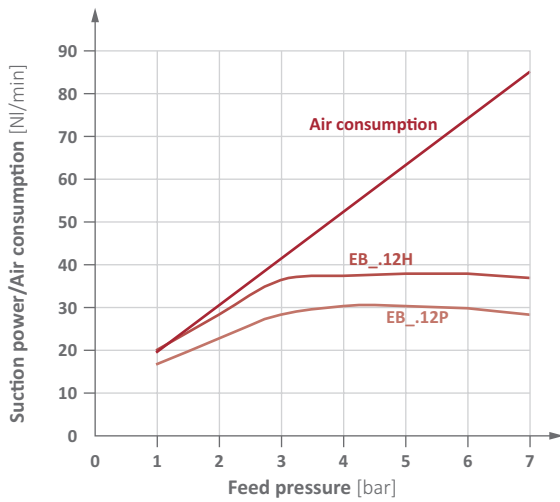

> Vacuum level against feed pressure

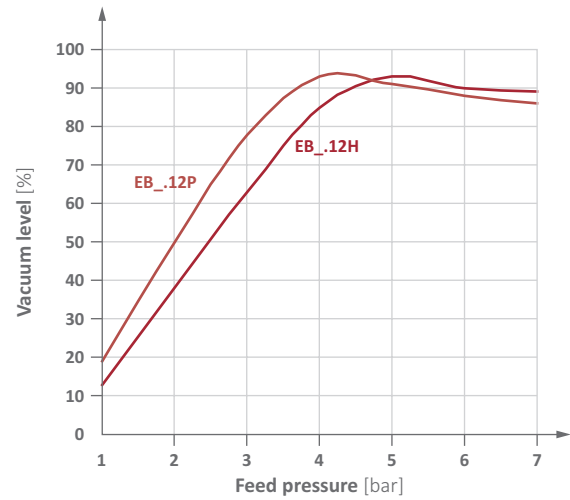

> Suction power and air consumption against feed pressure

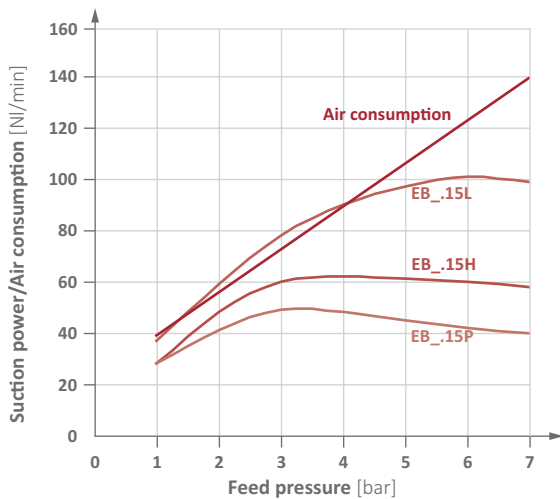

> Vacuum level against feed pressure

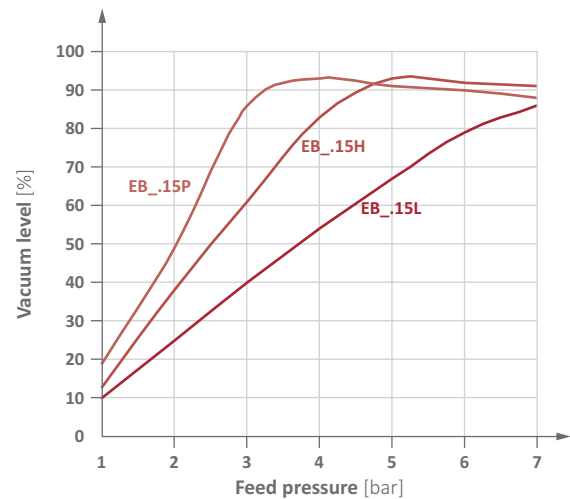

> Suction power and air consumption against feed pressure

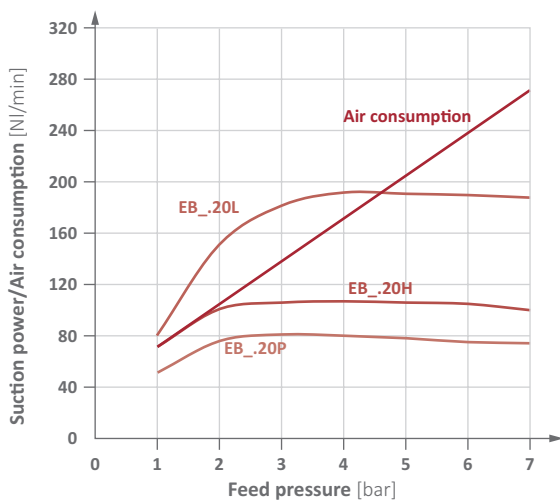

> Vacuum level against feed pressure

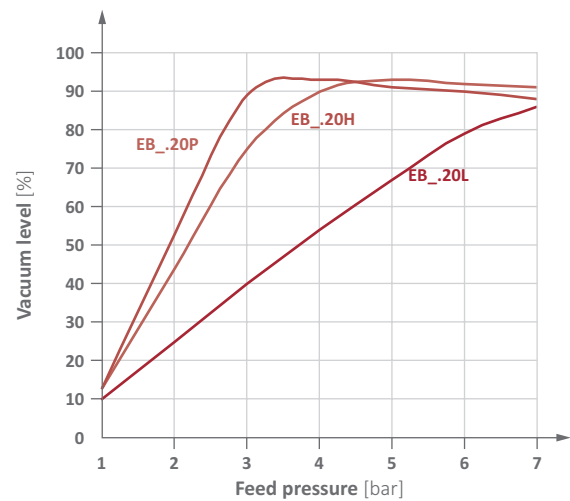



Suction power [NI/min] at vacuum level

Item no.	0 %	10 %	20 %	30 %	40 %	50 %	60 %	70 %	80 %	90 %
EBO.05H.4	7	6.2	5.4	4.6	3.8	3	2.2	1.5	0.7	--
EBO.07H.1	13	11.6	10.1	8.8	7.5	5.9	4.2	3	1.6	0.4
EBO.10H.1	28	25	22	18.9	15.9	12.9	9.9	6.9	3.9	0.9
EBO.12H.1	38	33.9	29.8	25.7	21.6	17.5	13.4	9.3	5.3	1.2
EBO.05L.4	12	10.8	9	7.5	5.5	4	2.5	0.8	--	--
EBO.07L.1	26	22	18.2	14	10	6.3	2.4	--	--	--
EBO.10L.1	42	35.6	29.3	22.9	16.5	10.2	3.8	--	--	--
EBO.07P.1	10.5	9.3	8.1	7	5.8	4.6	3.5	2.2	1.1	--
EBO.10P.1	21	18.7	16.4	14	11.8	9.5	7.1	4.8	2.5	0.2
EBO.12P.1	27	24	21	18.1	15.1	12	9.2	6.2	3.3	0.3
EBO.05H.4-S	7	6.2	5.4	4.6	3.8	3	2.2	1.5	0.7	--
EBO.07H.1-S	13	11.6	10.1	8.8	7.5	5.9	4.2	3	1.6	0.4
EBO.10H.1-S	28	25	22	18.9	15.9	12.9	9.9	6.9	3.9	0.9
EBO.12H.1-S	38	33.9	29.8	25.7	21.6	17.5	13.4	9.3	5.3	1.2
EBO.05L.4-S	12	10.8	9	7.5	5.5	4	2.5	0.8	--	--
EBO.10L.1-S	42	35.6	29.3	22.9	16.5	10.2	3.8	--	--	--
EBO.07P.1-S	10.5	9.3	8.1	7	5.8	4.6	3.5	2.2	1.1	--
EBO.10P.1-S	21	18.7	16.4	14	11.8	9.5	7.1	4.8	2.5	0.2
EBO.12P.1-S	27	24	21	18.1	15.1	12	9.2	6.2	3.3	0.3